

The 20 Series from TREPKO have been designed as semi-automatic filling and closing machines for pre-formed containers. Designed for customers whose required output level doesn't warrant a fully automatic machine the series is a cost effective option for the filling & sealing smaller containers.

The machine requires an operator to manually place the empty containers into a rotary turntable. As the operator rotates the turntable, containers can be volumetrically filled via an optional single head volumetric depositing system, then a pre-cut diaphragm is placed before being sealed to the container. The operator manually removes the filled and sealed container to repeat cycle.

The output of this machine can reach between 12-15 containers per minute (720-900 containers per hour) however it is the operator that controls the actual machine output rate.

The machine can be supplied with change parts for extra container sizes. All change parts are designed for a quick changeover times to minimise downtime. A different machine frame size is available to cater for larger container sizes.

A special version of the 20 Series, the 22S, has been designed for the closing and sealing of cardboard sandwich skillets.



## 20 series

semi-automatic filling & closing machines



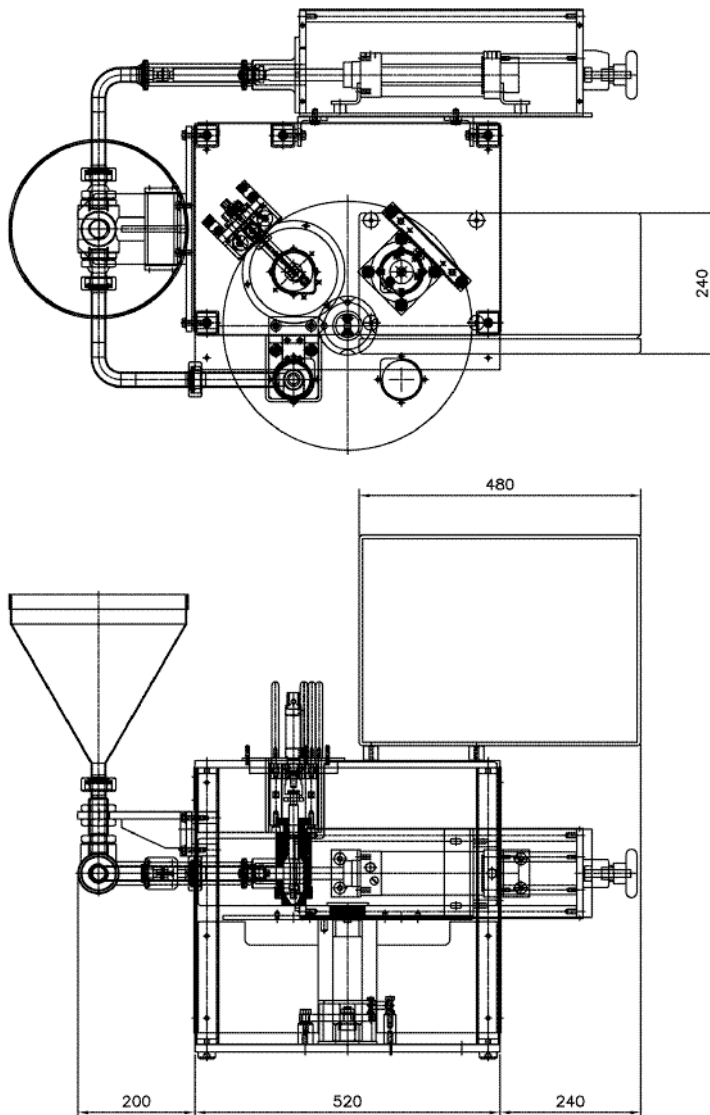

Machine type	21 KS	21 KS with doser	22 S
<b>Output*</b>			
- cups/min	12-16	12-16	16-20
- cups/hour	720-960	720-960	960-1200
<b>Services</b>	1	1	2
- electrical	240 V AC + N, 13A		
- compressed air (l/min)	250	320	65
Machine weight (kg)	100	150	150
Dimensions L x W x H (mm)	560 x 540 x 900	750 x 1000 x 900	1130 x 850 x 730

\* - subject to operator's speed

